





**CommandeX** is a leading wholesale provider of security screen systems and complementary products. Proudly 100% Australian owned, we supply to over 200 dealers across Australia, who are all committed to providing quality products and service.

We command the best in products, service and guarantee.

We pride ourselves on providing the highest quality security screens and frames, with contemporary design and state of the art technology, guaranteed to last.

# Contents



04

Security Screens  
Security Screen Doors  
Window Security Screens

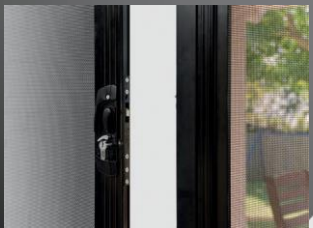

08

Security Screen Systems

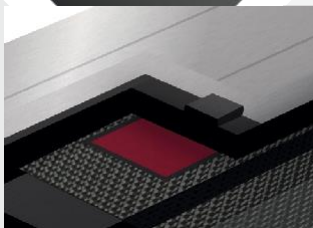

10

Design & Testing  
Patented Fixing System &  
Australian Security Standards  
Comparison Table & Colour Range



12

Safety Screens

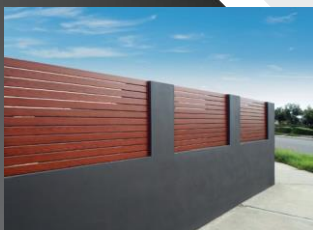

13

Aluminium Slat Fencing

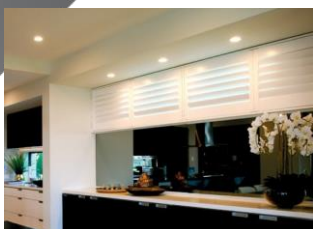

14

Plantation Shutters

# Security Screens

Safety. Security. Style. Our highly evolved security combines innovative contemporary design and state-of-the-art technology providing houses, multi-story dwellings, and commercial buildings across Australia with safety, security and style.

These durable security screens allow you to maximise passive cooling by making it safe to open every door and window to its full extent – and keep it open – without interrupting views.

Each security screen is custom made in Australia to precise door or window measurements and professionally installed by local dealers.

## Features

- Highly tensioned mesh
- No mid rails obstructing your view
- Complies with Australian Security Standards
- Custom built in Australia to suit a wide range of door and window openings

Innovative design, strength and durability make our security screens versatile and functional in a range of applications including:

- Hinged and sliding doors
- French doors
- Stacking doors (double and triple)
- Fixed windows
- Hinged and sliding windows
- Patio enclosures
- Fallsafe screens
- Fire & Emergency Escape Security screens
- Shop fronts
- Balustrade
- Cyclone screens





### Impenetrable Security Screen Doors

Our security screen doors are custom made to fit any door style and size.

A patented tensioning tool enables our screens to be manufactured for most large openings using one piece of mesh, meaning you can avoid horizontal mid rails commonly used with many security doors on the market.

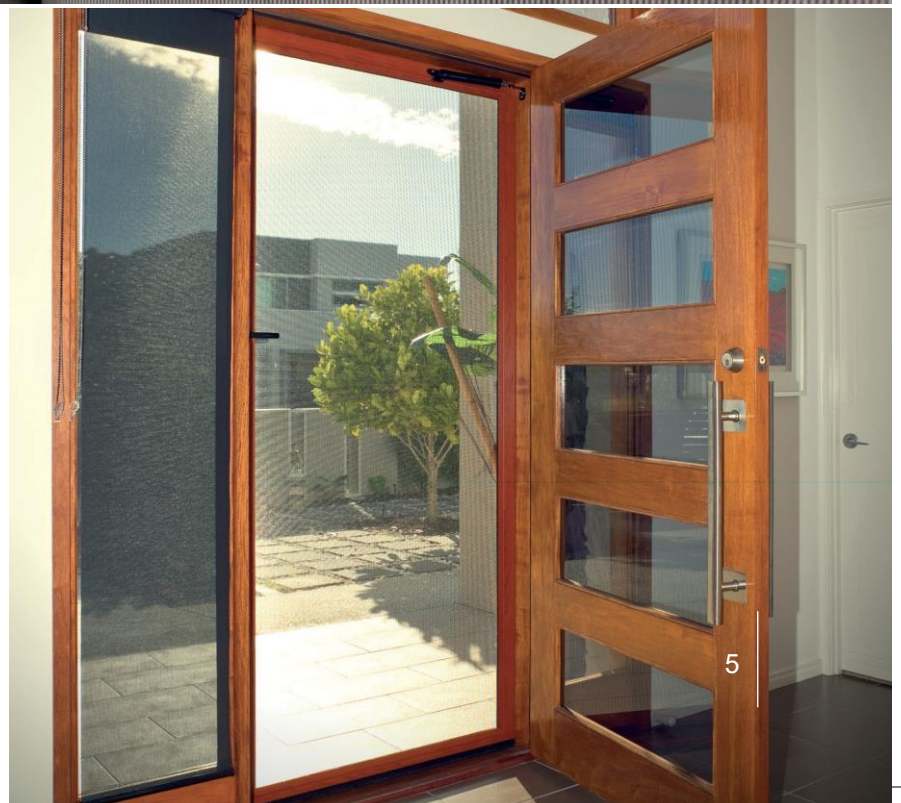



Feel safe and secure with our extensive range of Security Screen Windows

We protect windows openings of all sizes. Our security screens suit a range of applications including fixed, sliding, casement and awning windows.

## Plan your exit with our Fire & Emergency Escape Screens

- Complies with Australian Security Standards
- Quick and keyless opening from the inside
- Exceptional external security
- Optional outward swinging, inward swinging and sliding

It is important to determine an emergency escape, particularly when the entire home is screened. Our Fire & Emergency Escape security screens allow for a quick and keyless escape from the inside while providing full security from the outside.

These exceptionally strong security screens were innovatively designed with safety and practicality in mind.

The Fire & Emergency Escape security screen is available in outward swinging, inward swinging and sliding.

---

CommandeX dealers are industry experts in residential and commercial security screening solutions.

---

## Fully open your window with Kids Fallsafe Screens

- Meets Building Code legislation
- No need for a window lock restricting the opening to 12.5cm

A great choice for bedrooms and high traffic areas where occupants would like to fully open their window while kids play.

The National Construction Code (NCC) set legislation that window 2 metres above ground floor cannot open more than 12.5 cm unless the opening is protected to withhold 25kg of pressure in three different points.

Available in 4 mesh infill options:

- BasiX safety screen
- Xceed security screen\*
- SecureView security screen\*
- SaltWaterSeries security screen\*

When installed by a licensed installer, Kids Fallsafe Screens comply with this code.\*\*

\* Independently tested to exceed Australian Standards 5039-2023. Classified as a security screens as well as Fallsafe Screens.

\*\* Certification can be conducted by some dealers after installation. Check with your dealer to confirm they offer this service.



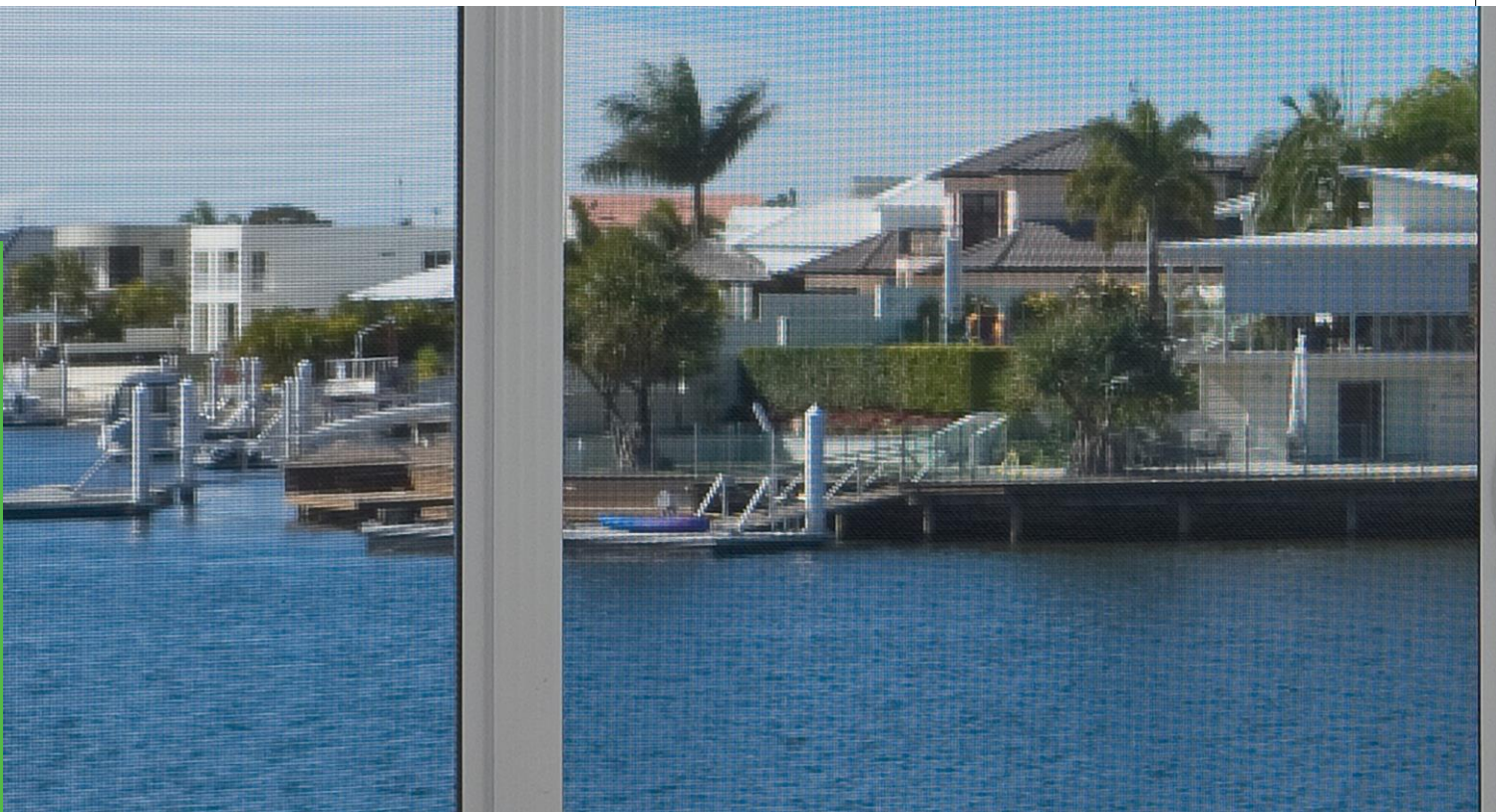

# Security Screen Systems

Custom Crafted. Understated Elegance.  
Choose the right security screen product for you.

CommandeX's range of security screen systems include our top of the range SecureView Eclix and coastal SaltWaterSeries woven stainless steel security screens, and our economical Xceed perforated aluminium screens, which is a superior alternative to the dated Diamond Grille.

All our security screens offer a wide range of features to meet Australian Standards AS5039-2023, while SecureView Eclix and SaltWaterSeries meet additional testing to ensure it continues to protect homes in cyclone, fire and corrosion prone areas.

---

Whichever CommandeX security screen product you choose, you can be confident it is custom crafted by expert technicians to suit your individual home, office or building requirements.

---

Xceed security screens are made from an extremely durable perforated aluminium sheet and extruded aluminium frame using a patented fixing method.

Perforated aluminium screens are a modern and more secure replacement for dated Diamond Grilles and a less expensive alternative to the premium woven stainless steel mesh.

Xceed offers a wide range of features to meet Australian Standards, has the corrosion resistant properties of aluminium, and act as a sun shade to reduce heat.

Due to its structural grade alloy, the Xceed perforated aluminium is thinner and stronger than the commonly used architectural grade aluminium. As a result, Xceed security screens deliver greater see-through visibility.

**Product Features and Benefits**

- Reduce heat and glare
- Corrosion resistant

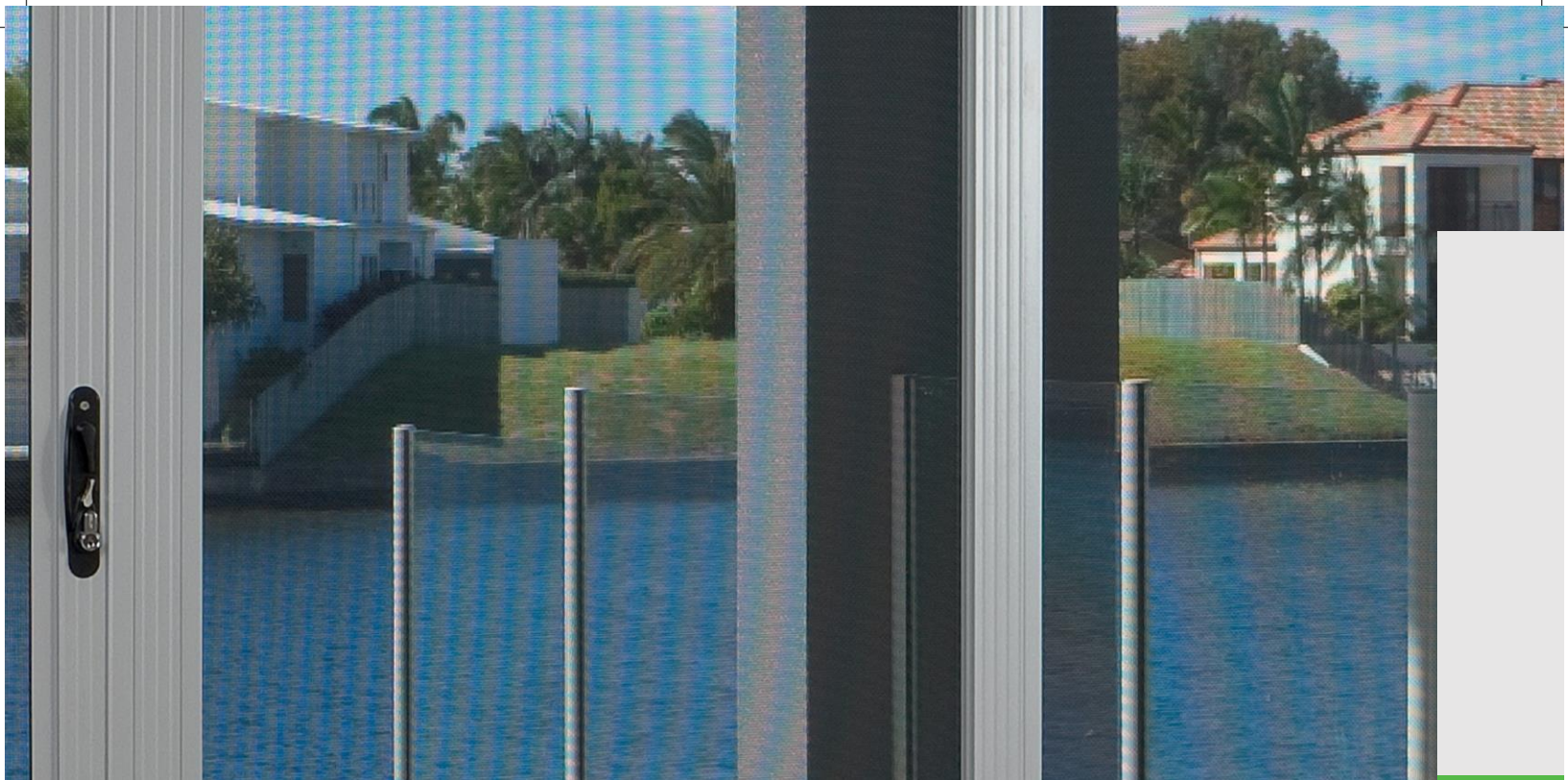

**Most Popular**

**SecureView** X  
Ecliptx 316 Stainless Security

**11**  
Eleven Year Standard Warranty

**15**  
Fifteen Year Extended Warranty\*

SecureView Ecliptx security mesh is made from 0.8mm 316 marine grade stainless steel, expertly woven in state-of-the-art facilities, and extruded aluminium frame using a patented fixing method.

Superior to its 304 steel counterpart, SecureView Ecliptx is selected for its superb strength, durability and resistance to corrosion, embers and flying debris.

SecureView Ecliptx gives you ultimate security, clear unobstructed views, without compromising on the aesthetics of your building.

**Product Features and Benefits**

- Enjoy clear unobstructed views
- Maximum strength and durability
- Patented innovation
- Resistant to corrosion, embers and flying debris

**Specialty**

**SaltWaterSeries** X  
SecureView 316 Stainless Security for Extreme Environments

**1**  
One Year Standard Warranty

**20**  
Twenty Year Extended Warranty\*

SaltWaterSeries security doors and windows are made from 316 marine grade stainless steel woven mesh, specifically powder coated for harsh conditions. The mesh is chosen for its superb strength, durability and corrosion resistance, and is far superior to the 304 steel mesh on the market.

SaltWaterSeries is designed for optimum performance and durability in extreme environments including:

- Coastal areas within 500m from the coastline or up to 2 km for properties located on an escarpment, where prevailing wind will carry salt air
- Iron rich red dust prone areas
- Heavy industrial areas
- Enjoy clear unobstructed views
- Maximum strength and durability
- Patented innovation
- Resistant to corrosion, embers and flying debris

**Your Commercial Partner**

To specify SecureView Ecliptx, SaltWaterSeries and Xceed security screens download specifications at [www.commandex.com.au](http://www.commandex.com.au)

Alternatively contact us for a Commercial information Pack and discover how CommandeX can help you deliver outstanding projects.

# Design & Testing

## Patented Fixing System

Our SecureView Eclipx, SaltWaterSeries and Xceed security screens use a unique Australian Patented fixing method that maintains unsurpassed strength and durability.

### 1. 3M™ VHB™ Acrylic Bonding

All our security screens are free from mechanical fixings such as old-fashioned screws and rivets. Instead, they employ VHB high performance chemical bonding technology to create effortless strength.

The acrylic chemistry of the VHB adhesive delivers exceptional durability while its viscoelasticity provides superior energy absorbing properties which helps to eliminate stress points.

### 2. Sleek Aluminium Frame

Our extruded aluminium frame system is crafted to deliver a lightweight solution without compromising on strength.

The frame features gold accredited Interpon™ powder coating that delivers a durable finish in a versatile range of colours including the latest Colorbond™ colours.

Solid aluminium stakes are used to fortify each corner join to provide steadfast strength.

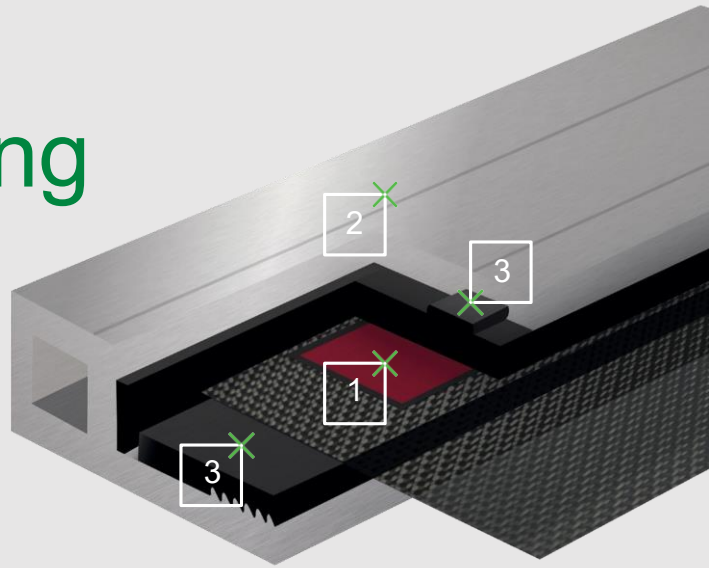

### 3. Innovative Keyway Fixing System

Our unique two-part wedge system has been designed to create the precise pressure required to activate the VHB™ adhesive to its full potential. This VHB™ chemical bonding is proven to have the strength to replace rivets.

Both wedges are made from UV stabilised PVC to yield superior durability over time.

Unlike screw-clamp or riveted systems, all our screens use innovative technology that provides clear spacing between the security screen infill and aluminium frame. This eliminates the opportunity for galvanic corrosion, which occurs when dissimilar metals contact.

## Performance That Surpasses Australian Security Standards

The Australian Standards (AS5039 – 2023) stipulate a range of scientific tests that a security product must pass in order to remain in this class.

These tests ensure the intrinsic strength and structural integrity of our manufactured security doors and windows are maintained. SecureView, Xceed and SaltWaterSeries are independently tested and surpass these standards.

Australian Standards (AS5039 – 2023)

- Knife Shear Test
- Pull Test
- Anti-Jemmy Test
- Impact Test
- Probe Test\*
- Shear test\*

\*N/A due to the hole aperture being far less than the test requirement.

Further information on each of these Australian Standards tests are available at [www.commandex.com.au](http://www.commandex.com.au)

SecureView Eclipx and SaltWaterSeries security screens surpass additional testing to achieve:

Aluminium Frame Tests (AS1866:2024 & AS3715 – 2025) 60603 T5 powder coated to a minimum thickness of 60um

Neutral Salt Spray Tests  
AS2331.3.1

Bushfire Protection  
AS3959-2018 satisfying the requirements for bushfire attack level (BAL) 12.5,19,29,40.

Fire Attenuation Test  
Australian Standard AS1530.4-2014, Appendix B7 achieving 46.6% reduction in radiant heat flux between the inside and outside of the product.

Cyclonic Screen Test  
AS1170.2-2021 resisting a 4kg, 100mm x 50mm timber projectile travelling at 30 metres per second (108 kph) surpassing the standard test of 15 metres per second.

## Security Screen Product Comparison



Features	Economical	Most Popular	Specialty
Mesh infill	Perforated, structural grade aluminium panels. Offering increased privacy, security and corrosion resistance.	Our best-selling high tensile, corrosion resistant, 316 marine-grade stainless steel security screen mesh.	High tensile, corrosion resistant 316 stainless steel featuring a protective heavy duty powder coating for coastal properties
3 Point Locking System	Optional	Yes	Yes
Patented Fixing System	Yes	Yes	Yes
Airflow	Excellent	Excellent	Excellent
Hole Aperture	2.20mm	1.575mm	1.57mm
Mesh Thickness	1.6mm	.8mm	.81mm
Insect Protection	Great	Excellent	Excellent
Visibility	Great	Excellent	Excellent
Pet door options available*	Yes	Yes	Yes
Manufacturer's Warranty	5 yr standard warranty 7 yr extended warranty**	11 yr standard warranty 15 yr extended warranty**	1 yr standard warranty 20 yr extended warranty**
<b>Testing</b>			
Security Grade Australian Standard (AS5039)	Yes, only when fitted with a 3 Point locking system	Yes, only when fitted with a 3 Point locking system	Yes, only when fitted with a 3 Point locking system
Aluminium Frame Tests	Pass	Pass	Pass
Cyclone Screen Test	Untested	Pass	Pass
Fire Rated	Untested	Pass	Pass
Neutral Salt Spray Test	Untested	1,000 hours	3,000 hours
Stainless Mesh Tests	Untested	Pass	Pass

\*Once a pet door is installed it no longer meets Australian Security standards and is considered a safety door.

\*\*Terms and conditions apply. Visit [www.commandex.com.au/product-warranty](http://www.commandex.com.au/product-warranty) for warranty terms.

To order a mesh sample visit [www.commandex.com.au](http://www.commandex.com.au)

## Colour Chart

Select from our range of standard colours including wood effect, or we can custom match the colour of your choice.

To view our online colour simulator visit:  
[www.commandex.com.au/colour-selector](http://www.commandex.com.au/colour-selector)

*Note:* All colours above are available however the standard colour range varies by product. These colours are for reference only and are an approximate of the true colours. The quality, type and settings of the output device used to display this page will also affect the visible colour.

ANODIC NATURAL MATT	ANOTEC DARK GREY	APO GREY	CHARCOAL	CUSTOM BLACK	DEEP OCEAN
DUNE	HAMMERSLEY BROWN	JASPER	MONUMENT	PALLADIUM SILVER	PAPERBARK
PEARL WHITE	PRIMROSE	STONE BEIGE	SURFMIST	ULTRA SILVER	WHITE BIRCH
WOODLAND GREY	BRONZE ANODISED	CLEAR ANODISED	SHALE GREY	TEXTURA BLACK	WESTERN RED CEDAR (WOOD EFFECT*)

\*Popular non standard colour.



# Safety Screens

BasiX safety screens are an attractive and cost effective entry point into the woven stainless mesh screen range.

BasiX safety screen offers a visual deterrent for intruders while offering long lasting pet resistant mesh and insect protection.

Our safety screens are made from a strong .71mm 316 Marine Grade stainless steel safety mesh infill, fixed to an extruded aluminium frame using CommandeX's patented fixing system. This assembly process provides a modern look.

The woven mesh hole aperture is 1.406mm, designed to keep out the tiniest creatures, including most sand flies. If you need more security for your home, refer to our security screen range which exceeds Australian Standards 5039-2023.

BasiX can be used in a range of applications including:

- Sliding, Hinged and Stacking Doors
- Fixed, Hinged and Sliding Window Screens
- Fall safe Screens or fall prevention screens are designed for high windows to ensure that the screen can withstand 25 kg of pressure in three different points. This ensures no one can fall out of the window when it is left wide open.
- Patio Enclosures to create a durable insect free outdoor space.

## TECHNICAL SPECIFICATIONS



Features	
Mesh infill	316 marine grade stainless steel, woven barrier mesh
3 Point Locking System	Optional
Patented Fixing System	No
Mesh Thickness	.71mm
Airflow	Excellent
Hole Aperture	1.406mm
Insect Protection	Excellent
Attractive, Sleek Look	Excellent
Pet door options available	Yes
Manufacturer's Warranty	5 yr standard warranty 7 yr extended warranty
Testing	
Tested to comply with Australian Standards 5039	No

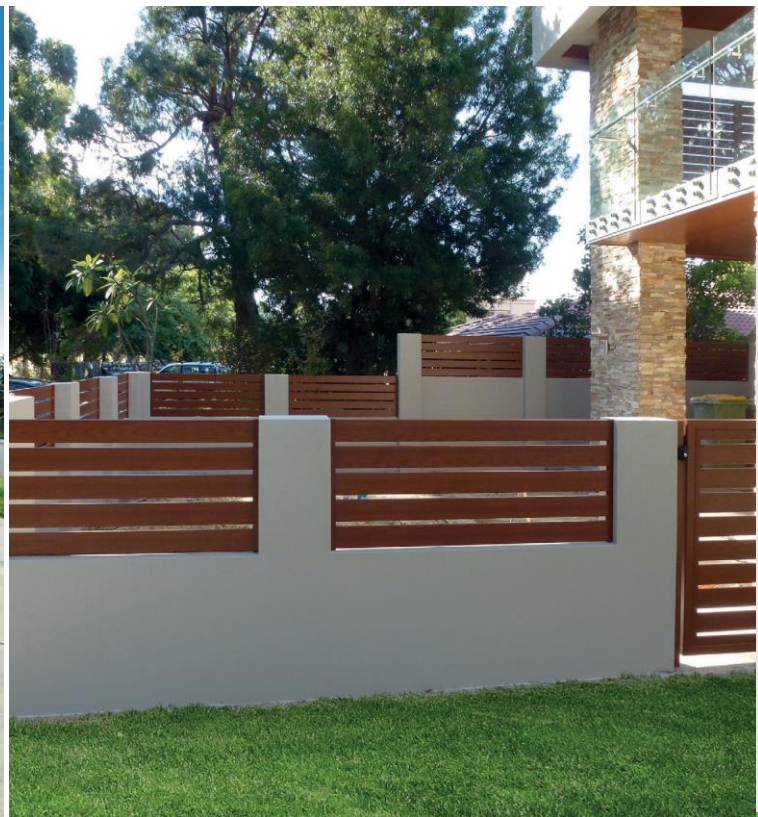
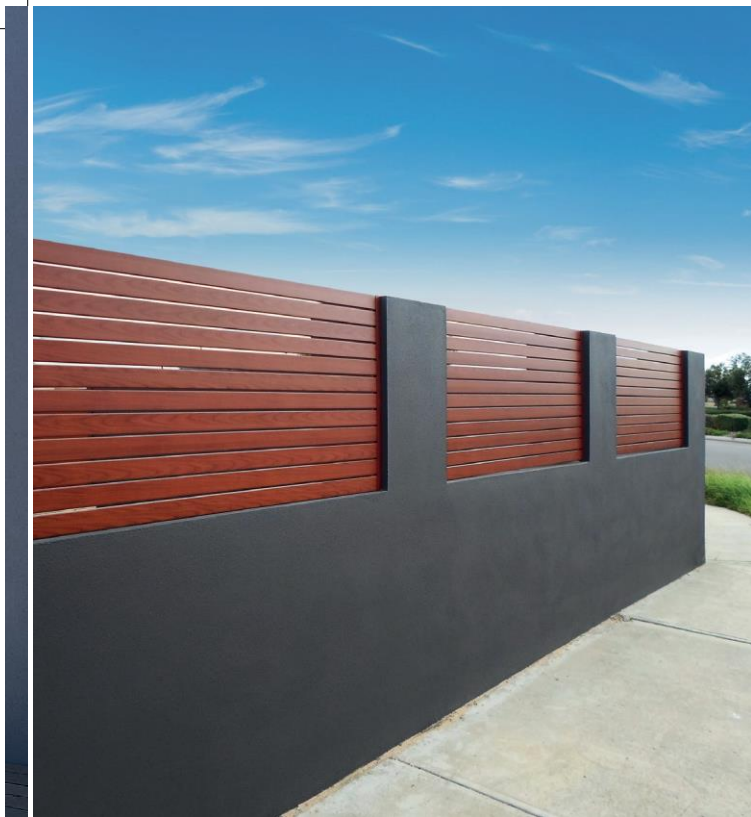

# Aluminium Slat Fencing

Xcell Aluminium Slat Fencing is fully customisable, allowing you to specify the privacy screen height, width and slat spacing.

Get peace of mind with one of the toughest products around:

- Rigorous Testing  
All specs in the Xcell range are built to meet the most stringent product testing.
- Reinforced Screwed Fixing  
Ensuring your Xcell product stays securely fastened, withstands the elements and offers an extended life cycle.
- Affordable Pricing  
Making the Xcell brand a viable alternative to DIY privacy screens.
- Guaranteed to Last  
All our Xcell privacy screens and gates are built to last, using superior strength components, and backed by an 11 year warranty.

Slatted aluminium privacy screens suit a range of mounting options:

- Brick Pier Infill Panels
- Screen Fencing
- Deck and/or Balcony Areas
- Utility Screens
- Carport & Patio Enclosures
- Window Screens
- Gates

## TECHNICAL SPECIFICATIONS

Slats: 65mm x 16mm

Privacy screen posts: 44mm x 44mm

Gate frame & posts: 50mm x 50mm

Slat spacing: fully customisable

Mounting location and panel size will determine if a mid rail or centre post is required.



# Plantation Shutters

Privacy with Style – Plantation Shutters offer a timeless window finish for both modern and traditional homes with a wide range of styles available.

The elliptical blades can be operated with ease by hand and adjusted for optimal privacy and energy efficiency. Choose from a range of materials, on trend colours, and installation and mounting options.

Our plantation shutters are custom made using quality materials and workmanship, guaranteed to last. Low thermal conductivity means you save on heating and cooling costs.

### Choose your material

	Plantation Timber	Fauxwood (PVC)
Warranty – Materials*	5 years	20 years
Warranty – Paint*	3 years	3 years
Water resistant	Moderate	Yes
Thermal conductivity	Low	Low
Termite & rot resistant	Yes	Yes
Sustainably sourced	Yes – <i>from plantation forests</i>	No

\* Terms and conditions apply



### Choose your colour

Our plantation shutters are painted or stained after manufacture for an optimal finish.

Fauxwood range of whites  
2 layers of polyurethane paint.

PURE WHITE	STAR WHITE	LOVE NOTE	ANTIQUÉ WHITE
WHITE CLOAK QTR	WITCH HAZEL	SOLAR FLIGHT	JASPER

Timber painted colours  
5 layers of polyurethane paint, lightly sanded between coats to ensure a smooth and even finish.

PURE WHITE	WITCH HAZEL	ANTIQUÉ WHITE	MONUMENT
WHITE CLOAK QTR	LOVE NOTE	JASPER	BLACK
STAR WHITE	SOLAR FLIGHT	SILHOUETTE	

Timber stain colours  
Where a Plantation Shutter is stained, the grain and any knot in the timber will be visible. This is considered a feature of the product.

NATURAL	GOLDEN OAK	CORDOVAN	WALNUT
---------	------------	----------	--------

### Choose your design

Our Plantation Shutters are custom made to suit any window size and shape.

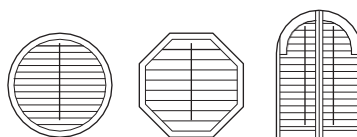

#### TECHNICAL SPECIFICATIONS

Shape: Special shaped shutters are available in addition to our standard rectangle shutter

Opening Options: Fixed, Hinged, Sliding and Bi-fold options are available

Blade Size:

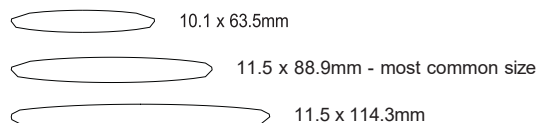

Mounting Method: Inside Mount or Outside Mount as determined by the window style

Midrail Height: Panels greater than 1800mm in height will require a midrail

Post Options: T-Post, Bay-Post and Corner-Post

Tilt Rod: Hidden tilt rod, Centre tilt rod and Offset tilt rod options available for both PVC and Timber shutters



Find your local CommandeX expert by calling  
**1300 720 838**

or visit us online to learn more  
[www.commandex.com.au](http://www.commandex.com.au)

Your local representative: